

Spread of Social Information and Dynamics of Social Transmission within *Drosophila* Groups

Marine Battesti,^{1,2} Celine Moreno,^{1,2} Dominique Joly,^{1,2} and Frederic Mery^{1,2,*}

¹Laboratoire Evolution, Génomes et Spéciation, CNRS-UPR 9034, 91198 Gif-sur-Yvette Cedex, France

²Université Paris-Sud 11, 91405 Orsay, France

Summary

Understanding how behavioral diversity arises and is maintained is central to evolutionary biology. Genetically based inheritance has been a predominant research focus of the last century; however, nongenetic inheritance, such as social transmission, has become a topic of increasing interest [1]. How social information impacts behavior depends on the balance between information gathered directly through personal experience versus that gleaned through social interactions and on the diffusion of this information within groups [2, 3]. We investigate how female *Drosophila melanogaster* use social information under seminatural conditions and whether this information can spread and be maintained within a group, a prerequisite for establishing behavioral transmission [4]. We show that oviposition site choice is heavily influenced by previous social interactions. Naive observer flies develop a preference for the same egg-laying medium as experienced demonstrator flies conditioned to avoid one of two equally rewarding media. Surprisingly, oviposition site preference was socially transmitted from demonstrators to observers even when they interacted in a cage with only unflavored, pure agar medium, and even when the observer flies had previous personal experience with both rewarding media. Our findings shed light on the diffusion process of social information within groups, on its maintenance, and ultimately, on the roots of behavioral local adaptation.

Results and Discussion

In *Drosophila*, deciding where to lay eggs can have a major impact on the development and survival of progeny and consequently on Darwinian fitness. Egg-laying site decisions are based on both genetic and environmental factors and can be modified by personal experience [5–7] and social cues such as aggregation pheromone [8, 9] or social interaction [10]. Recent experiments [10, 11] show that *Drosophila* can use social information to make oviposition decisions in the absence of other types of information. However, it is unclear how socially learned behavior can propagate and stabilize within a group and whether *Drosophila* actually use social information when directly interacting both with other individuals and with environmental factors. In the present study, we directly test whether oviposition site preference can spread and stabilize within groups of *Drosophila melanogaster*.

Our experiments all involved one or more of the following three steps. (1) A “conditioning” phase [5], in which flies

were trained in groups to associate an aversive gustatory cue with the flavor of one of two oviposition media (banana or strawberry) and therefore to avoid this flavored medium for egg laying. These conditioned flies were used as “demonstrators” that could potentially transmit their modified egg-laying preference to naive “observer” flies. (2) A “transmission” phase, in which observer naive flies were given the opportunity to directly interact with demonstrator flies and/or environmental cues (flavored media, eggs, aggregation pheromone). (3) A “test” phase, in which observers and demonstrators were separated, given fresh media, and left to make further egg-laying decisions. We measured a performance index (PI) at the end of the test phase (PI: the difference between the proportion of eggs laid on the banana medium when demonstrators were conditioned to avoid strawberry and the proportion of eggs laid on the banana medium when demonstrators were conditioned to avoid banana). A PI of 0 indicates no response to previous conditioning; a PI of 1 indicates complete avoidance of the previously aversive medium.

See the [Supplemental Information](#) available online for additional details on the materials, methods, and statistical analyses.

Conditioning Phase

The primary goal of the initial conditioning procedure was to confirm that the flies are capable of learning from environmental cues and, if so, to produce demonstrator females for two sets of subsequent experiments. After conditioning, the flies were shifted to a fresh cage with fresh media over a two-part 24 hr test phase (Figure 1). The PI for these conditioned females (Figure 1; $PI = 0.28 \pm 0.11$, $n = 60$, $F_{1,61} = 16.721$, $p < 0.001$) confirmed that the females did respond to the conditioning procedure even 24 hr postconditioning and that oviposition site preference can be modified by experience with environmental cues.

Experiment 1: Do *Drosophila* Females Use Social Information to Make Oviposition Site Choices?

Our first set of experiments was designed to determine whether flies use social information to make oviposition decisions when they have access to both social and individual information at the same time.

Naive Females Use Social Information to Make Oviposition Decisions

During the transmission phase, we placed four observers and eight demonstrators together in a cage with the two choices of oviposition media; observers were able to directly interact with the demonstrators, the other observers, or the environment by personally sampling both media. The oviposition site preference of observer flies during the test phase paralleled that of demonstrator flies with which they were caged during the transmission phase (Figure 2A; $PI = 0.28 \pm 0.08$, $n = 80$, $F_{1,77} = 11.49$, $p = 0.001$; demonstrator-observer comparison: $F_{1,156} = 0.002$, $p = 0.967$). This suggests that female flies use social information when making oviposition site decisions, even when they have the opportunity to gather personal information about their options.

*Correspondence: frederic.mery@legs.cnrs-gif.fr

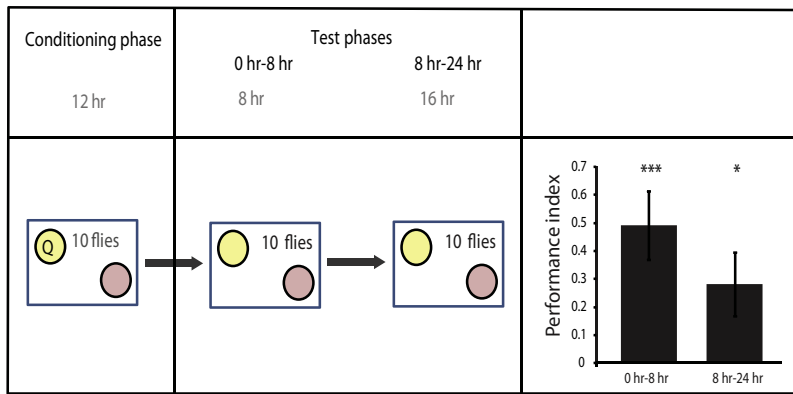

Figure 1. Description of Aversive Oviposition Conditioning to Generate “Demonstrator” Females and Performance Indexes of Flies during the Two Test Phases

After aversive oviposition conditioning, groups of ten flies were tested on fresh, flavored media without quinine over an 8 hr (0 hr–8 hr) and then a consecutive 16 hr (8 hr–24 hr) period. Yellow circles indicate banana-flavored media, pink circles indicate strawberry-flavored media, and empty circles indicate unflavored, pure agar media. Q indicates medium supplemented with quinine. Asterisks indicate a significant response to the conditioning: *** $p \leq 10^{-3}$, ** $p \leq 0.01$, * $p \leq 0.05$; $n = 60$ for all bars. Error bars represent \pm standard errors of the mean (SEM).

Naive Females Gather Information Directly from Experienced Females

The disproportionate presence of demonstrator eggs and aggregation pheromones on one media during the transmission phase may have been a cue that observers used to make egg-laying site decisions. The aggregation pheromone deposited by females during egg laying is well studied and known to influence egg-laying decisions. In a recent study, Sarin and Dukas [10] showed that *Drosophila* interacting with other mated flies on a single oviposition substrate develop an increased preference for this substrate. However, in their

study, the presence of aggregation pheromone alone was not enough to generate preference for a given site.

We tested whether the presence of eggs and potentially aggregation pheromone could induce long-term modification of oviposition site preference. During the transmission phase, we presented groups of four observer flies with the two media: one containing freshly laid eggs and one with none. No demonstrators were present during this phase. During the test phase, we transferred them to fresh cages with fresh media. Despite the potential effect of eggs and aggregation pheromone during the transmission phase, oviposition site preference during the

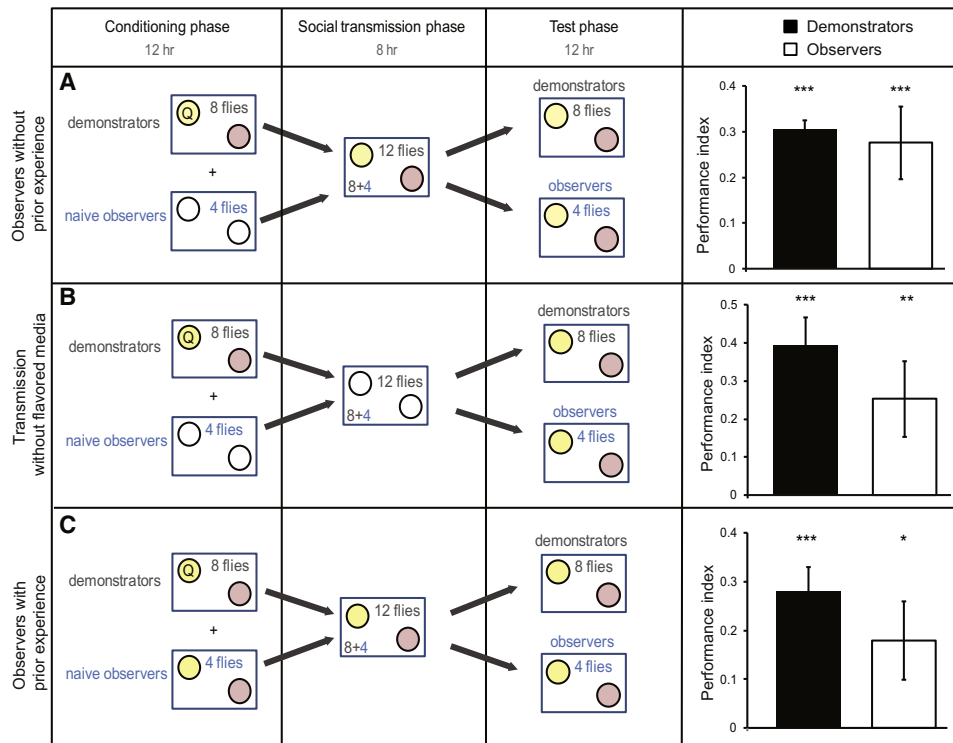

Figure 2. Social Transmission of Oviposition Site Preference with Performance Indexes of Demonstrators and Observers Measured at the End of the Test Phase

During the transmission phase, observer flies either had never experienced the oviposition media (A, B) or had already experienced the two flavored media (C). Transmission phase (B) was done in cages containing no flavored media. Circle colors are described in Figure 1. Asterisks indicate significant response to the initial conditioning (for demonstrators) or social transmission (for observers): *** $p \leq 10^{-3}$, ** $p \leq 0.01$, * $p \leq 0.05$. Observer groups without prior experience, $n = 80$; observer groups with prior experience, $n = 78$; observer groups in transmission phase without flavors, $n = 56$. Error bars represent \pm standard errors of the mean (SEM).

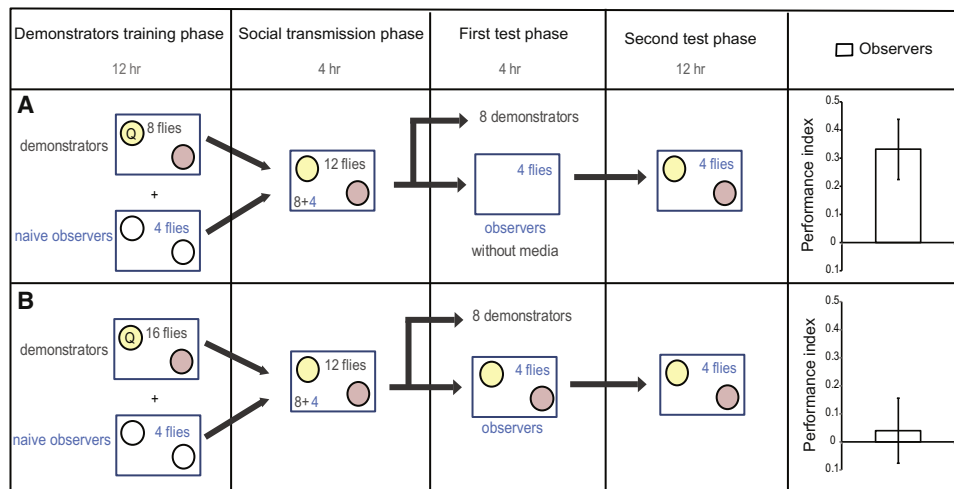

Figure 3. Stability of Socially Acquired Information when Flies Have the Opportunity to Later Acquire Personal Information

After a transmission phase, observer flies were introduced in cages containing either no oviposition media (A) or flavored media (B) for 4 hr. Circle colors are described in Figure 1. PIs were then calculated after an 8 hr test period in which all groups had access to flavored media. Asterisks indicate significant response to social interaction: *** $p \leq 10^{-3}$, ** $p \leq 0.01$, * $p \leq 0.05$.

test phase was not influenced by the previous presence of eggs in the absence of demonstrator flies (PI = 0.06 ± 0.04 , $n = 80$, $F_{1,77} = 1.124$, $p = 0.292$). This suggests that oviposition site preference is transmitted through direct interactions with demonstrators, not through the mere presence of eggs and aggregation pheromone.

Females Transmit Oviposition Site Preference even in the Absence of the Oviposition Site Choices

In vertebrates, most social transmission events occur via simple processes such as local or stimulus enhancement [12, 13], i.e., when the behavior of an individual attracts another individual to a particular place or stimulus. We therefore asked whether the presence of demonstrators on one of the flavored media was one of the mechanisms that influenced the preference of the observers in the previous tests. During the transmission phase, we placed both demonstrators and observers together in cages with two plates of odor-free, plain agar media rather than the flavored media. Therefore, the media itself provided no information about the demonstrators' conditioned preference. During the test phase, we separated the observers and demonstrators into new cages with fresh plates of the two flavored media (Figure 2B). Surprisingly, observer flies responded to the social interaction, and their preference matched that of their demonstrators (Figure 2B; PI = 0.25 ± 0.1 , $n = 56$, $F_{1,54} = 7.248$, $p = 0.009$; comparison of demonstrator-observer transmission without flavored media: $F_{1,112} = 0.276$, $p = 0.601$). This suggests that direct interaction with demonstrators is sufficient to generate social transmission and that the social transmission of information does not involve direct exposure to the flavored substrate.

Flies Use Social Cues to Choose Egg-Laying Sites even when They Have Personal Experience with the Substrates

Whether individuals choose to use social information may depend on several factors, such as previous experience [14]. We therefore asked whether observer flies would still use social information to make egg-laying decisions when they had experience with the oviposition substrates before interacting with the demonstrators. The experiment was similar to the first one described above except that while demonstrators

were being conditioned, observers were kept in a separate cage with the two flavored media (Figure 2C). Observers that had experience with the flavored media relied only slightly less on social information than did completely naive observers (compare Figure 2C with 2A; PI = 0.18 ± 0.08 , $n = 78$, $F_{1,76} = 4.9$, $p = 0.03$; comparison with-without experience: $F_{1,155} = 0.760$, $p = 0.385$). Even though observers had the opportunity to sample both media and determine that both are rewarding, they still modified their preference according to subsequent social interaction (Figure 2C).

Flies Stop Using Social Information when They Are Able to Easily Gather Personal Information

Finally, we asked about the stability of socially acquired information within a group when flies have the opportunity to accumulate personal information after social transmission. During the transmission phase, we placed demonstrators and observers together in a cage with the two flavored media for 4 hr. Then, during a 4 hr test phase, the groups of observer flies were randomly placed in fresh cages that contained either a choice of the two flavored media or no oviposition substrates. During a second 8 hr test phase, we replaced the media in all cages with the two flavored media. PI was high for those flies given no oviposition substrates during the first test phase (Figure 3A; PI = -0.33 ± 0.09 , $n = 38$, $F_{1,36} = 7.48$, $p = 0.01$). Flies given flavored media in the first test phase no longer showed any response to the initial social interaction (Figure 3B; PI = 0.04 ± 0.11 , $n = 38$, $F_{1,71} = 0.008$, $p = 0.928$). With time, observers had the opportunity to sample both media, accumulate personal information, and determine that both media were equally suitable. Thus, this result suggests that the flies exposed to flavored media did not simply forget the social information. The flies that were not exposed to the flavored agar media had no additional information about the quality of their oviposition site choices, and so continued to rely on the social information they had gathered during the transmission phase. In nonhuman animals, the maintenance of behavioral traditions depends on the balance between social and personal information. When the cost of gathering personal information is low, such as in our experimental conditions, the influence of social information may rapidly vanish at

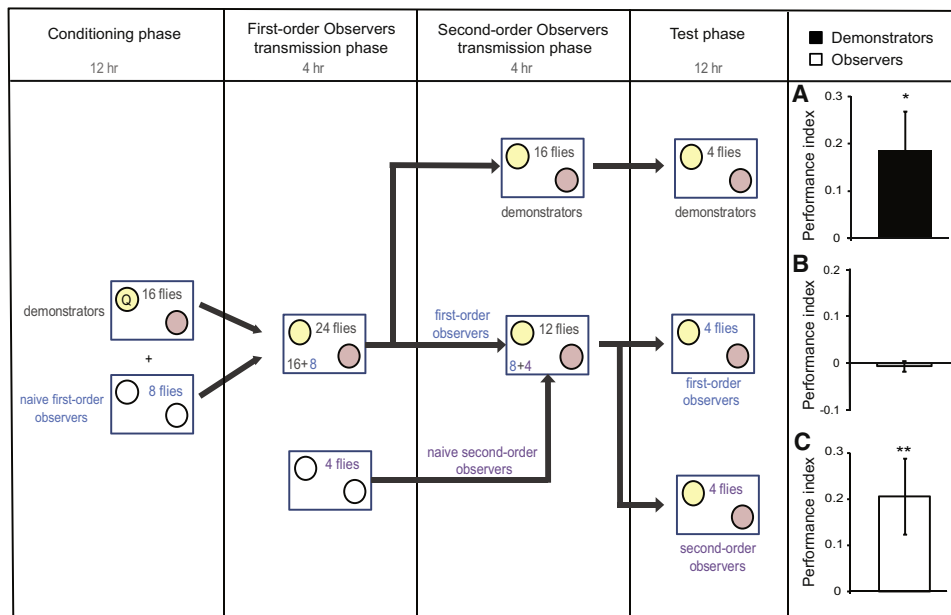

Figure 4. Transmission of Social Information from First-Order Observers to Second-Order Observers with Performance Indexes of Demonstrators, First-Order Observers, and Second-Order Observers

After conditioning, a group of demonstrators and a first group of naive observers were introduced into a new cage containing flavored media. First-order observers were then removed and introduced into a new cage with a group of second-order observers. Finally, all types of flies were placed in separate cages for a 12 hr test phase on fresh oviposition media. Circle colors are described in Figure 1. Asterisks indicate significant responses to the initial conditioning (for demonstrators) or social transmission (for observers): *** $p \leq 10^{-3}$, ** $p \leq 0.01$, * $p \leq 0.05$. Shown are (A) demonstrators groups, $n = 74$; (B) first-order observer groups, $n = 74$; (C) second-order observer groups, $n = 74$. Error bars represent \pm standard errors of the mean (SEM).

the individual level, especially in situations in which the choice of oviposition sites is arbitrary [2, 15, 16].

Experiment 2: Transmission of Oviposition Preference from First-Order Observers to Second-Order Observers

Considering the previous results, how social information will be maintained within a group may depend on the dynamics of group turnover. We tested whether social information transmitted from demonstrators to observers could again be passed from those observers to new, naive observers; this is crucial for understanding the stability of social information within a group. The experiment consisted of two consecutive transmission phases. During the first 8 hr transmission phase, groups of eight observers interacted with 16 demonstrators in cages containing the two flavored media. During the second transmission phase, these “first-order” observers were introduced to new cages containing four naive “second-order” observers. During the test phase, the demonstrators, first-order observers, and second-order observers were separated into new cages with fresh supplies of the two media. Second-order observers responded to the information they had gathered through their social interaction (Figure 4C; $PI = 0.20 \pm 0.08$, $n = 74$, $F_{1,72} = 6.938$, $p = 0.01$). At the end of the test phase, the PI of second-order observers equaled that of demonstrators, suggesting that social information can flow within a group from observer to observer and remain stable over time. However, first-order observers no longer showed a preference for one media over another (Figure 4B; $PI = -0.007 \pm 0.01$, $n = 74$, $F_{1,71} = 0.21$, $p = 0.999$). As in the first set of experiments, with time first-order observer flies may have sampled the media and determined that both were equally good. On the other hand, demonstrators that experienced the aversive media may have been more affected by

this strong negative experience and continue to show a response to the initial conditioning.

Our results may suggest that, at the level of the group, social information can persist over time if the dynamics of the social turnover meet certain criteria. Social information can flow as long as the group contains both individuals that carry arbitrary information and individuals that have no a priori preference. Once all information has been shared among all individuals in a group, social exchanges are reduced and outweighed by the accumulation of personal information and arbitrary preference is progressively lost. However, continuous introduction of naive individuals within a group should fuel social transmission and maintain the exchange of social information at the group level. Clearly more work is required for a better understanding of the dynamics of social information within a group.

General Conclusions

These results suggest that social information can spread within a group of *Drosophila* and may be maintained under certain conditions. The maintenance of egg-laying site preference, however, seems to depend on the dynamics of group turnover. The mechanism for how information about “good” oviposition substrate is transferred to observer flies is still an open question. We showed evidence that neither the position of the eggs on a medium nor the accumulation of aggregation pheromone affect observer preference. Interaction with demonstrators was a necessary and sufficient condition to modify oviposition behavior. It is possible that demonstrator flies collect the odor of the “good” medium on their bodies during the initial conditioning phase and that the observers are using these olfactory cues to make oviposition site decisions during the transmission phase. Several studies on social

animals, such as rodents, honeybees, and bumblebees, point to the importance of olfactory cues in the context of socially induced food preference. Naive rats show increased preference for a certain diet after smelling this same diet on the breath of a conspecific [17, 18]. In bumblebees, recruiting individuals produce specific pheromones that mix with a specific floral scent and stimulate other bees to forage on that same flower type [19].

Our results also suggest that the timing between when personal and social information are gathered may play an important role in *Drosophila* decision making. Studies on vertebrates and invertebrates predict that animals should ignore social information when they have prior, relevant personal information [3, 14, 20–22]. Here, prior personal information did not affect the response to social interaction but the accumulation of subsequent personal information progressively impacted oviposition site choice.

Taken altogether, these experiments show that *D. melanogaster* rely more heavily on social information than on personal information when both co-occur and even when they already have personal experience in the environment. When choosing between two equally rewarding oviposition media during the test phase of our experiments, observers tended to emulate the choice of demonstrators with which they spent time during the transmission phase. Considering the short lifespan of *Drosophila* in nature, rapidly adopting the behavior of the majority may provide an individual with cues to choices that are locally adaptive and prevent costly trial and error. Though it has been generally accepted that animals should use a combination of social and personal information to make behavioral decisions, a recent study challenged this view and showed that heavily relying on social information can be a successful strategy even when the costs of gathering personal information are low [23]. This “conformist” social learning should be favored in organisms with life histories like that of *Drosophila* and could potentially maintain similarities within groups and differences between groups [24], and possibly even play a role in maintaining behavioral diversity and driving local adaptation. By using a “simple” model organism, this study illuminates potential mechanisms of social transmission and sheds light on the evolution of information transfer.

Supplemental Information

Supplemental Information includes Supplemental Experimental Procedures and can be found with this article online at doi:10.1016/j.cub.2011.12.050.

Acknowledgments

We would like to thank J. Foucaud for providing the fly strain, J. Burns, M. Sokolowski, and S. Wardrop for useful help on the manuscript, and C. Wicker-Thomas and B. Roland for help with the experiment. This work was supported by the European Research Council under the European Community's Seventh Framework Programme (FP7/2007–2013)/ERC Grant agreement no. 209540 to F.M.

Received: August 31, 2011

Revised: December 1, 2011

Accepted: December 21, 2011

Published online: January 19, 2012

References

1. Danchin, E., Charmantier, A., Champagne, F.A., Mesoudi, A., Pujol, B., and Blanchet, S. (2011). Beyond DNA: integrating inclusive inheritance into an extended theory of evolution. *Nat. Rev. Genet.* 12, 475–486.
2. Thornton, A., and Clutton-Brock, T. (2011). Social learning and the development of individual and group behaviour in mammal societies. *Philos. Trans. R. Soc. Lond. B Biol. Sci.* 366, 978–987.
3. Kendal, R., Coolen, I., and Laland, K. (2009). Adaptive trade-offs in the use of social and personal information. In *Cognitive Ecology II*, R. Dukas and J.M. Ratcliffe, eds. (Chicago: University of Chicago Press), pp. 249–272.
4. Laland, K., Richerson, P.J., and Boyd, E.F. (1993). Animal social learning: towards a new theoretical approach. In *Perspectives in Ethology, Volume 10*, P.P.G. Bateson, P.H. Klopfer, and N.S. Thomson, eds. (New York: Plenum), pp. 249–277.
5. Mery, F., and Kawecki, T.J. (2002). Experimental evolution of learning ability in fruit flies. *Proc. Natl. Acad. Sci. USA* 99, 14274–14279.
6. Yang, C.H., Belawat, P., Hafen, E., Jan, L.Y., and Jan, Y.N. (2008). *Drosophila* egg-laying site selection as a system to study simple decision-making processes. *Science* 319, 1679–1683.
7. Miller, P.M., Saltz, J.B., Cochrane, V.A., Marcinkowski, C.M., Mobin, R., and Turner, T.L. (2011). Natural variation in decision-making behavior in *Drosophila melanogaster*. *PLoS ONE* 6, e16436.
8. Wertheim, B., Allemand, R., Vet, L.E.M., and Dicke, M. (2006). Effects of aggregation pheromone on individual behaviour and food web interactions: a field study on *Drosophila*. *Ecol. Entomol.* 31, 216–226.
9. Wertheim, B., van Baalen, E.J.A., Dicke, M., and Vet, L.E.M. (2005). Pheromone-mediated aggregation in nonsocial arthropods: an evolutionary ecological perspective. *Annu. Rev. Entomol.* 50, 321–346.
10. Sarin, S., and Dukas, R. (2009). Social learning about egg-laying substrates in fruitflies. *Proc. Biol. Sci.* 276, 4323–4328.
11. Mery, F., Varela, S.A.M., Danchin, E., Blanchet, S., Parejo, D., Coolen, I., and Wagner, R.H. (2009). Public versus personal information for mate copying in an invertebrate. *Curr. Biol.* 19, 730–734.
12. Thorpe, W.H. (1956). The language of birds. *Sci. Am.* 195, 128–138.
13. Franz, M., and Matthews, L.J. (2010). Social enhancement can create adaptive, arbitrary and maladaptive cultural traditions. *Proc. Biol. Sci.* 277, 3363–3372.
14. Leadbeater, E., and Chittka, L. (2005). A new mode of information transfer in foraging bumblebees? *Curr. Biol.* 15, R447–R448.
15. Thornton, A., and Malapert, A. (2009). The rise and fall of an arbitrary tradition: an experiment with wild meerkats. *Proc. Biol. Sci.* 276, 1269–1276.
16. Rieucau, G., and Giraldeau, L.A. (2011). Exploring the costs and benefits of social information use: an appraisal of current experimental evidence. *Philos. Trans. R. Soc. Lond. B Biol. Sci.* 366, 949–957.
17. Galef, B.G., Kennett, D.J., and Stein, M. (1985). Demonstrator influence on observer diet preference—Effects of simple exposure and the presence of a demonstrator. *Anim. Learn. Behav.* 13, 25–30.
18. Galef, B.G., Jr., and Giraldeau, L.A. (2001). Social influences on foraging in vertebrates: causal mechanisms and adaptive functions. *Anim. Behav.* 61, 3–15.
19. Molet, M., Chittka, L., and Raine, N.E. (2009). How floral odours are learned inside the bumblebee (*Bombus terrestris*) nest. *Naturwissenschaften* 96, 213–219.
20. Coolen, I., van Bergen, Y., Day, R.L., and Laland, K.N. (2003). Species difference in adaptive use of public information in sticklebacks. *Proc. Biol. Sci.* 270, 2413–2419.
21. van Bergen, Y., Coolen, I., and Laland, K.N. (2004). Nine-spined sticklebacks exploit the most reliable source when public and private information conflict. *Proc. Biol. Sci.* 271, 957–962.
22. Kendal, R.L., Coolen, I., and Laland, K.N. (2004). The role of conformity in foraging when personal and social information conflict. *Behav. Ecol.* 15, 269–277.
23. Rendell, L., Boyd, R., Cownden, D., Enquist, M., Eriksson, K., Feldman, M.W., Fogarty, L., Ghirlanda, S., Lillicrap, T., and Laland, K.N. (2010). Why copy others? Insights from the social learning strategies tournament. *Science* 328, 208–213.
24. Boyd, R., and Richerson, P.J. (1985). *Culture and the Evolutionary Process* (Chicago, IL: University of Chicago Press).